

A-A (1:1)

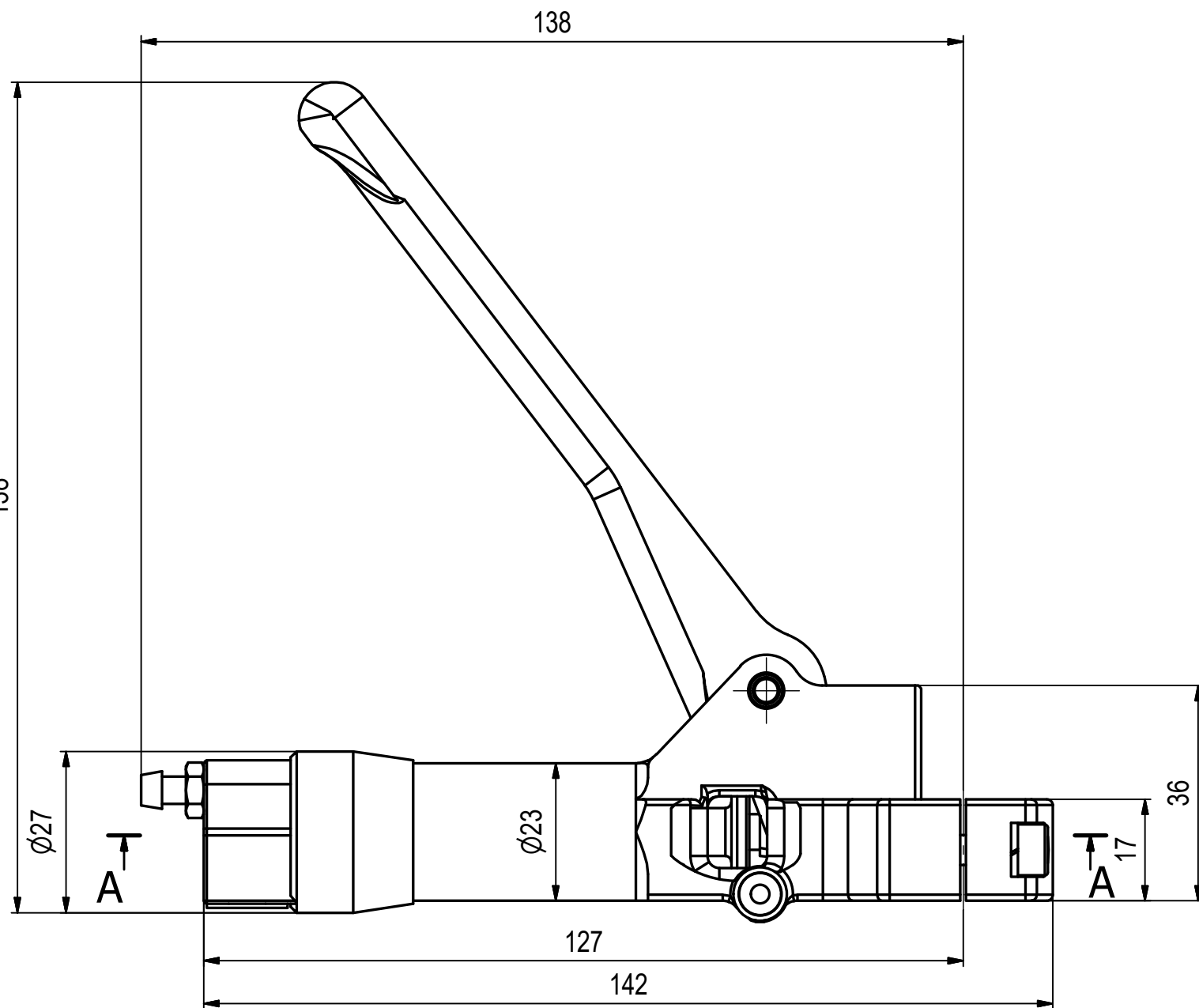
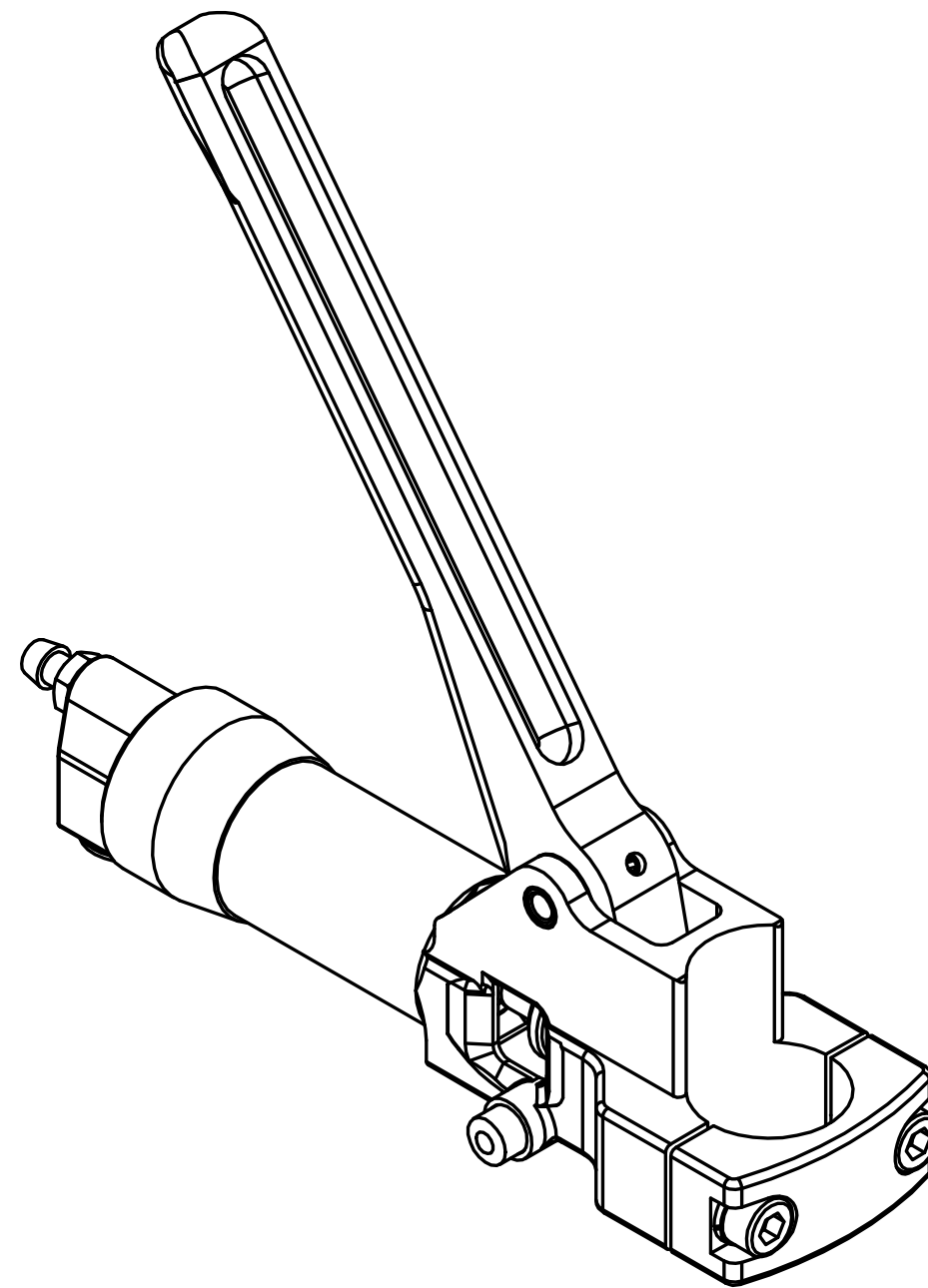
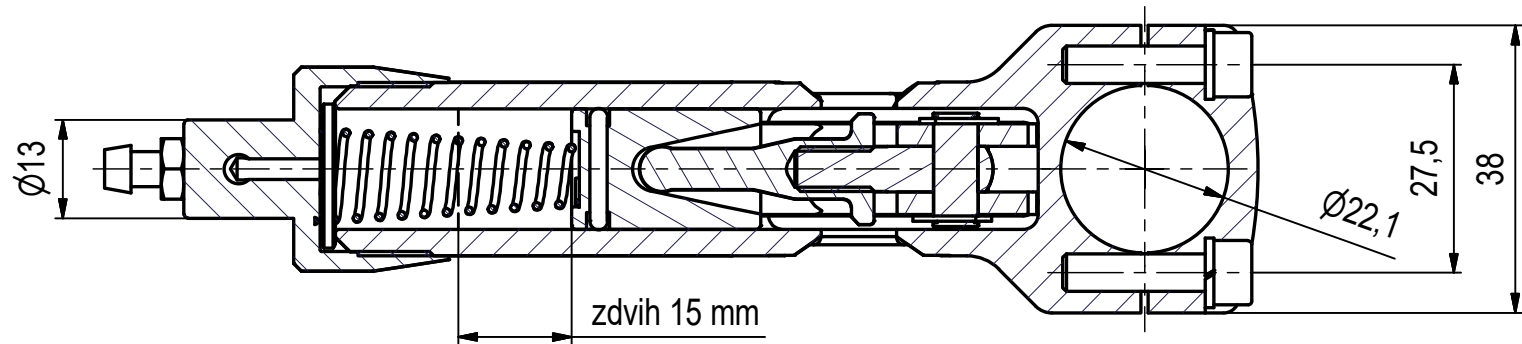

Materiál															
Polotovar															
Tep. zpracování															
Povrch. úprava															
ks/1 prov.:				Plnění součástí:											
VYPRACOVAL LP		DNE 22.11.2012		INDEX		ZMENA		DATUM		PODPIS					
KONTROLOVAL J. Kašpar															
TECHNOLOG															
SCHVÁLIL		DNE													
Měřítko		P	S	V	HF	NF	BP	BK	K	D	Z	PROMITANI	ISO 2768-mK	HMOTN. kg	
1:1														T.O.	
KÁŠPAR a synové- strojírna Kalmar s.r.o.		CELEK:		NÁZEV		HLAVNÍ BRZDOVÝ VÁLEC		Číslo sestavy		K-418A-000		Index		List: 1	
						Ø16 NA KNIPL, ROVNÝ, z		Číslo výkresu				List: 1			